

CREMONA E25 FLAT 1 PONTO ACIONAMENTO INTERNO

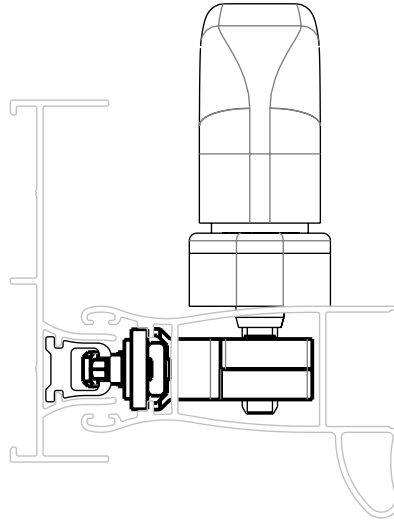

APLICAÇÃO



CARACTERÍSTICAS

CODIFICAÇÃO			
VERSÃO	COR	CÓDIGO	CATÁLOGO
300mm	BCO	9212610	CREE25FL1PIN300BCO
	PTF	9212611	CREE25FL1PIN300PTF

OBSERVAÇÕES:

- MAÇANETA, KIT HASTE E CONTRAFECHO SÃO VENDIDOS SEPARADAMENTE.

COMPOSIÇÃO/CARACTERÍSTICAS:

- VARETA EXTERNA/INTERNA: ALUMÍNIO;
- ACIONAMENTO: ZAMAK;
- PARAFUSOS: AÇO INOX.

USINAGEM

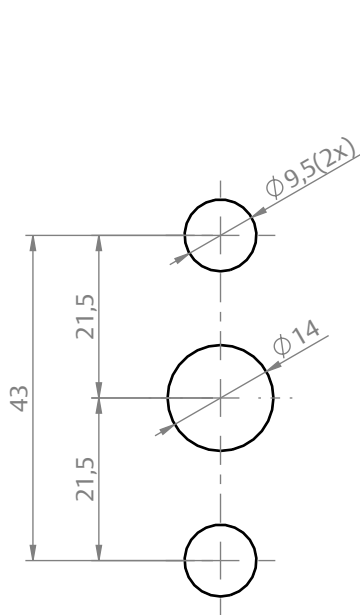

ESCALA 1:1

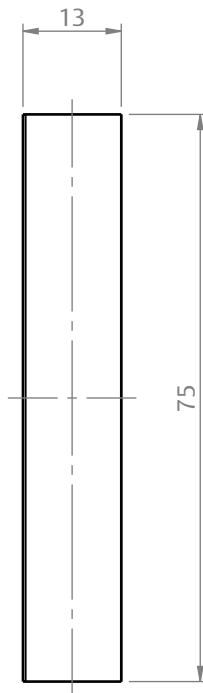

DIMENSÕES

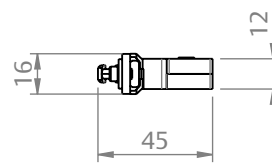
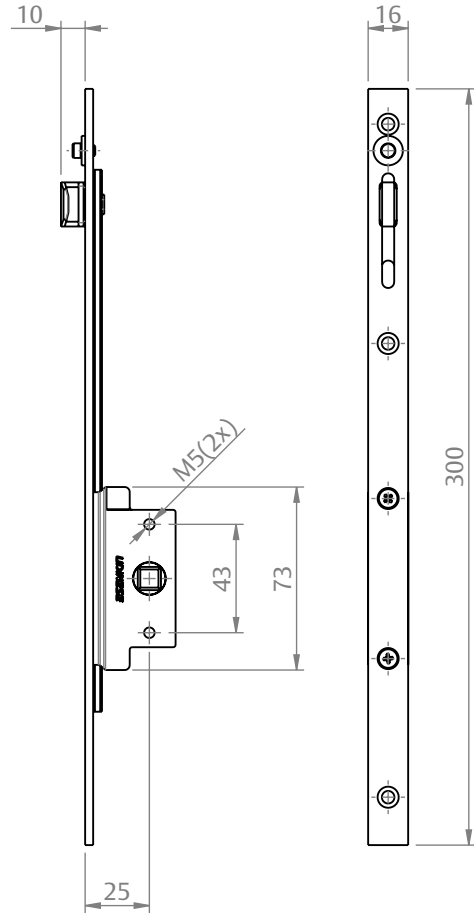

ESCALA 1:3

PORTA E JANELA
DE CORRER
INOVA

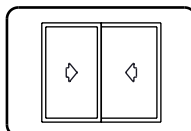

UDINESE
ASSA ABLOY