

TAMPA PINGADEIRA MASSIMA S NYL C/1PAR

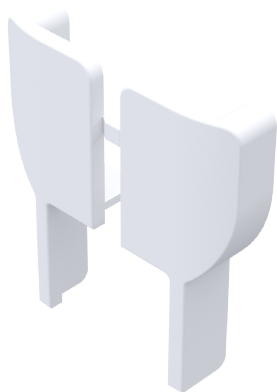

CARACTERÍSTICAS

CODIFICAÇÃO		
COR	CÓDIGO	CATÁLOGO
BCO	9302803	TAMPINGMASSNYBCO1PA
CZA	9302804	TAMPINGMASSNYCZA1PA
PRT	9302805	TAMPINGMASSNYPRT1PA

OBSERVAÇÕES

COMPOSIÇÃO/CARACTERÍSTICAS:

- TAMPA: POLÍMERO.

APLICAÇÃO

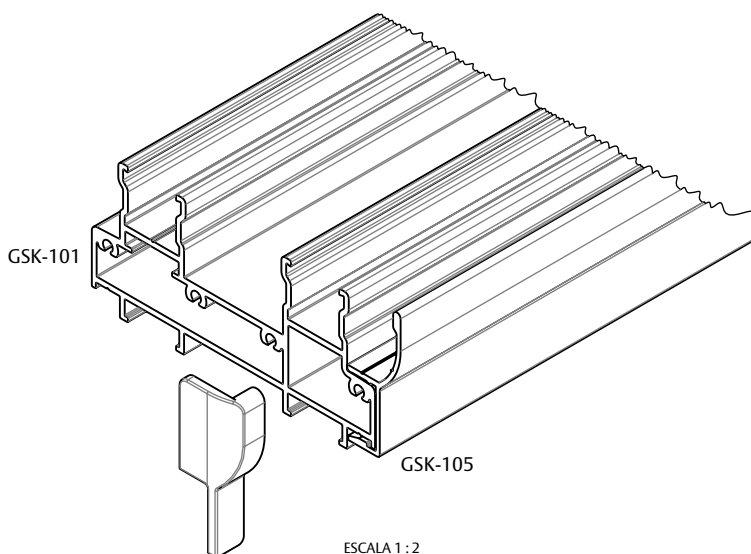

ESCALA 1 : 2

DIMENSÕES

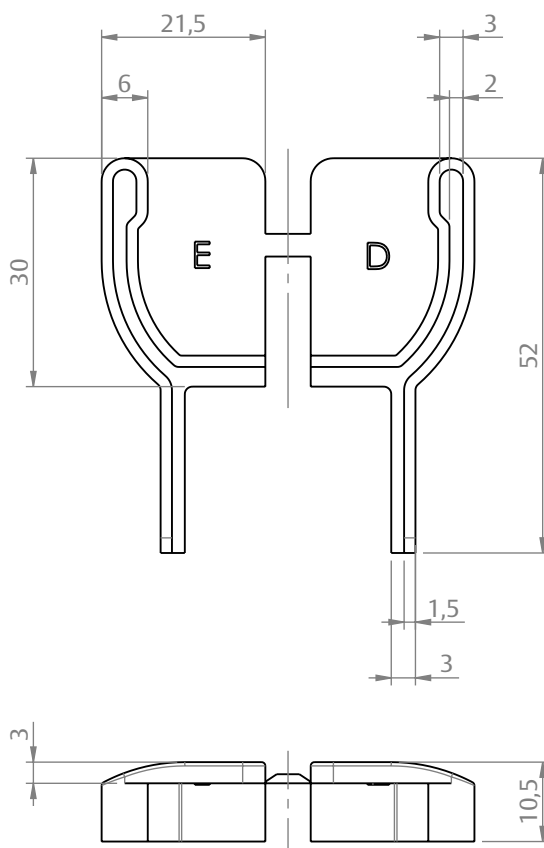

ESCALA 1 : 1

PORTA DE CORRER

LOCK S

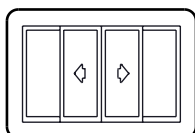

UDINESE
ASSA ABLOY