

TRAVA FOLHA HASTE CAMARÃO PRT



CARACTERÍSTICAS

CODIFICAÇÃO			
COR	CÓDIGO	CATÁLOGO	SISTEMISTA
PRT	9303184	TRAFHASCAMPRT	OCOS-PONTCE-001-NAT

OBSERVAÇÕES

COMPOSIÇÃO/CARACTERÍSTICAS:

- TRAVA FOLHA: POLÍMERO/AÇO.

APLICAÇÃO

VISTA SUPERIOR

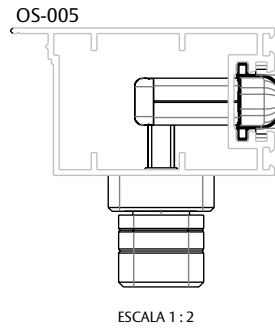

VISTA FRONTAL

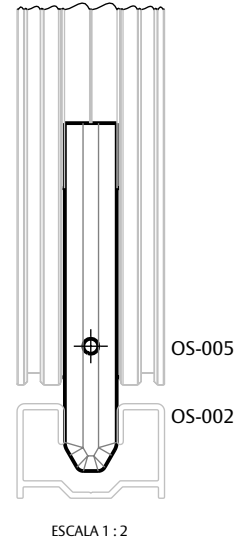

DIMENSÕES

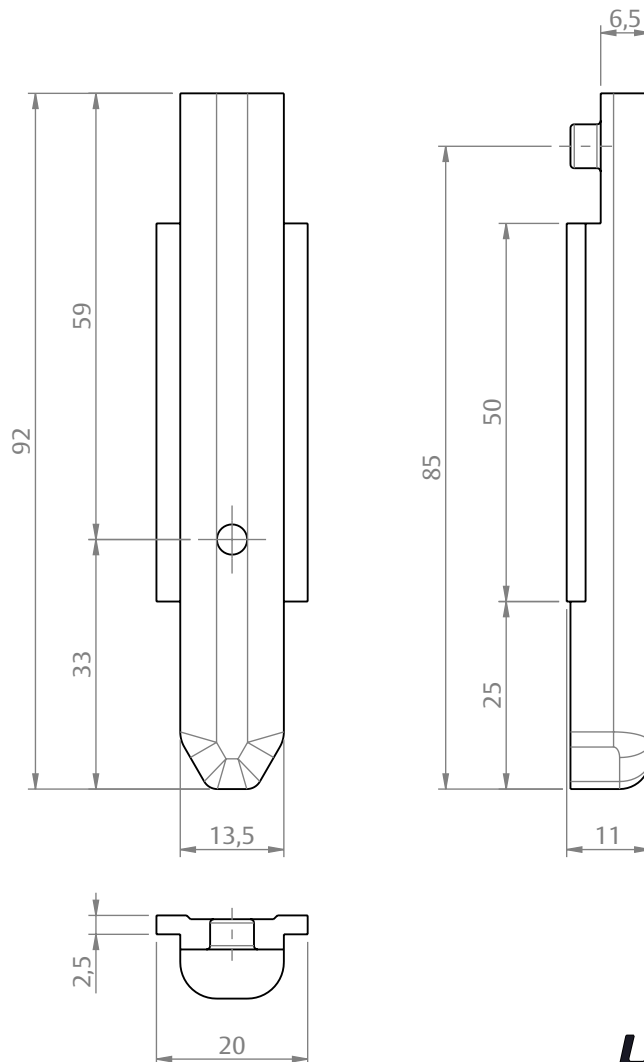

PORTA CAMARÃO
OLGA SIERRA

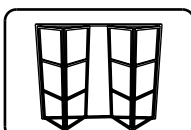

UDINESE
ASSA ABLOY