

BATEDEIRA BAT FLEX

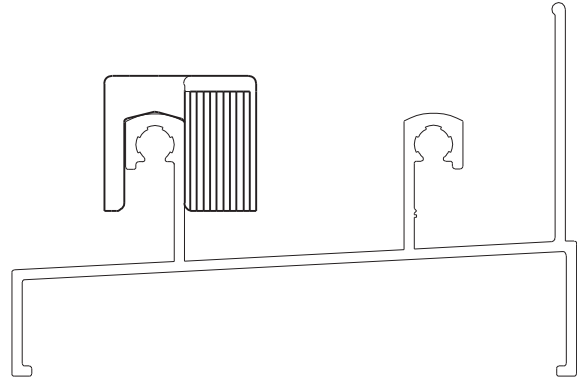

Aplicação



escala 1:1

Características

Componentes	Matéria-prima
Batedeira	Polímero
Tampa	Polímero
Amortecedor	EPDM

Componente de fixação	Dimensão	Qtde.
Parafuso	4,2x13 cha/ph/inox	2/pç

Embalagem	10 batedeiras
	10 tampas
	10 amortecedores
	20 parafusos

Cor	Codificação	
	Udinese	Catálogo
PRT	9301963	BATFLPRTE10
BCO	9301964	BATFLBCOE10

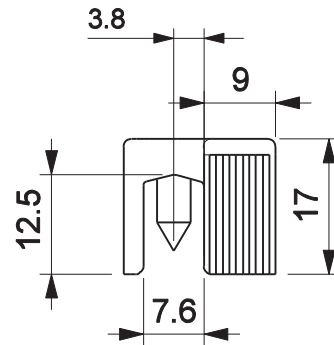
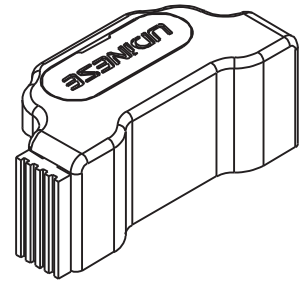
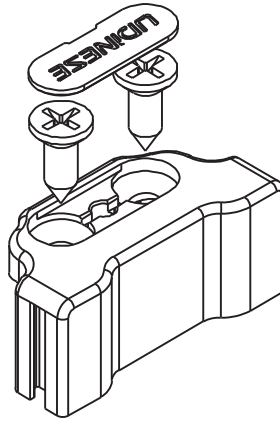

Diametro de Usinagem:

2 furos de Ø 3,6mm

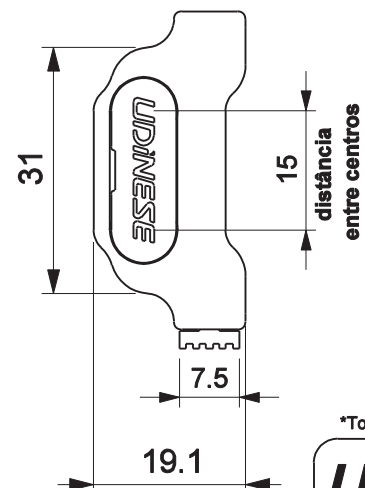
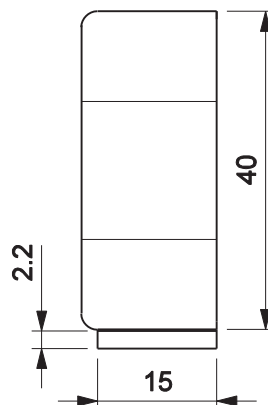
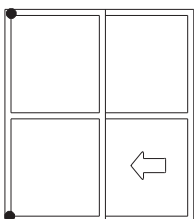

*Todas as medidas em mm

PORTA / JANELA DE CORRER
LINHA SUPREMA

escala 1:1

UDINESE