

# CAIXA DRENO C/ ESFERA RNR 3.3 DRN-0001 NYL

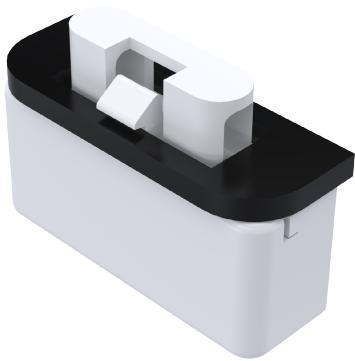

## APLICAÇÃO

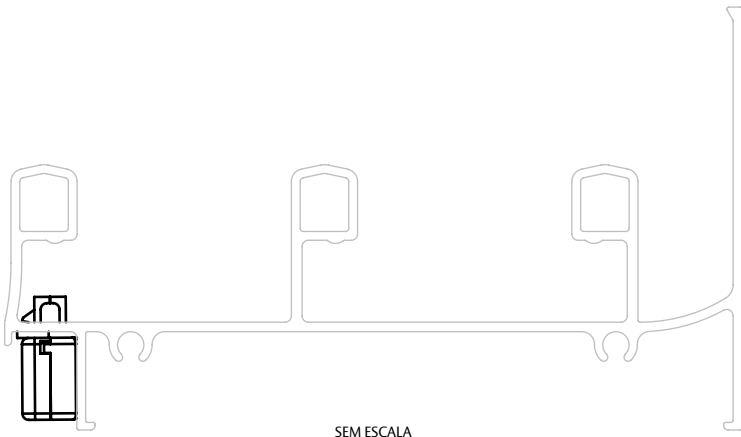

SEM ESCALA

## CARACTERÍSTICAS

CODIFICAÇÃO		
COR	CÓDIGO	CATÁLOGO
BCO	9302734	DREESFRNR33NYBCOE2
PRT	9302502	DREESFRNR33NYPRTE2

## OBSERVAÇÕES

### COMPOSIÇÃO/CARACTERÍSTICAS:

- CAIXA DRENO: POLÍMERO;
- ESFERA: POLIPROPILENO;
- ESPUMA: POLIÉSTER.

## USINAGEM

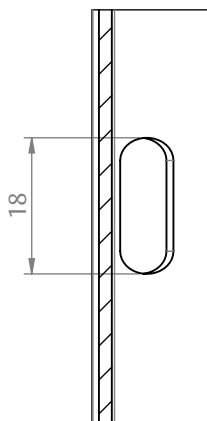
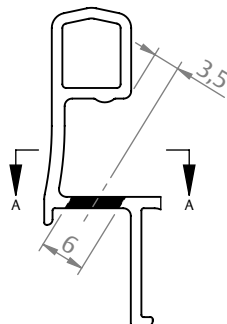

SEÇÃO A-A  
ESCALA 1 : 1

## DIMENSÕES

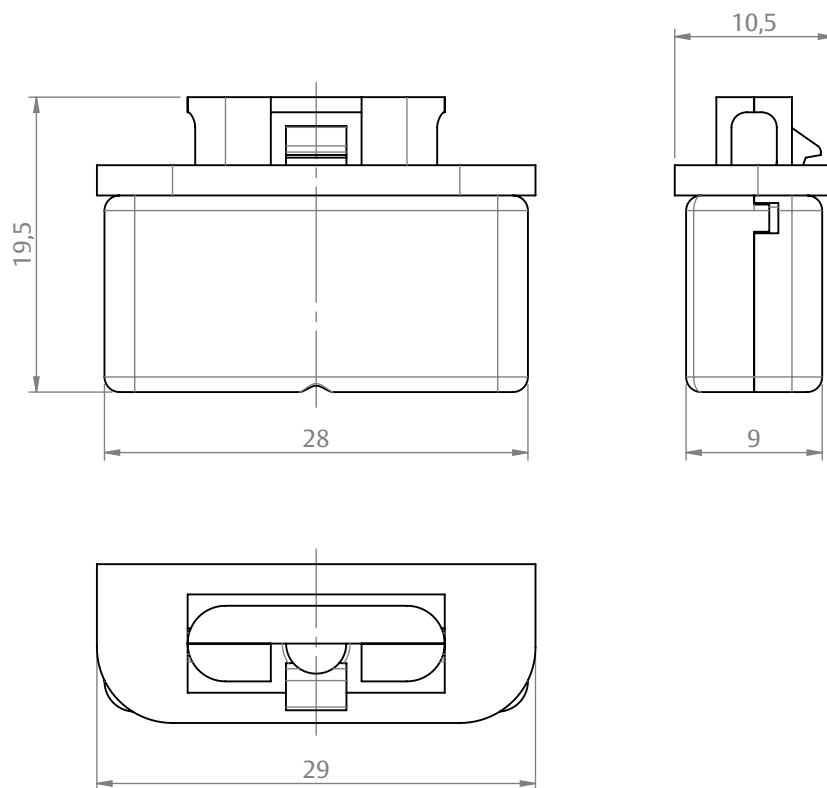

ESCALA 2 : 1

PORTA E JANELA  
DE CORRER  
RENOIR 3.3

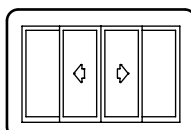

**UDINESE**  
**ASSA ABLOY**