

CAIXA DRENO SD2507 NY

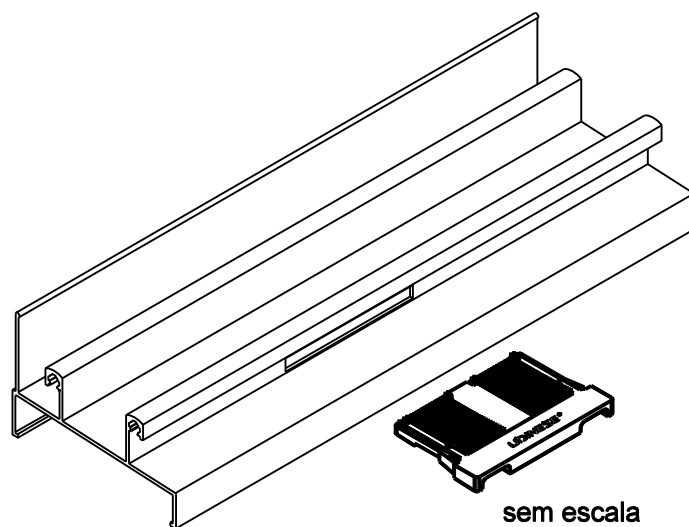

Aplicação



Características

Componentes	Matéria-prima
Caixa dreno	Polímero
Escova de vedação	Polipropileno

Embalagem	10 drenos
	20 escovas

Codificação		
Cor	Udinese	Catálogo
PRT	9300867	DRES2507E10
BCO	9301209	DRES2507BCOE10

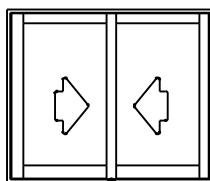
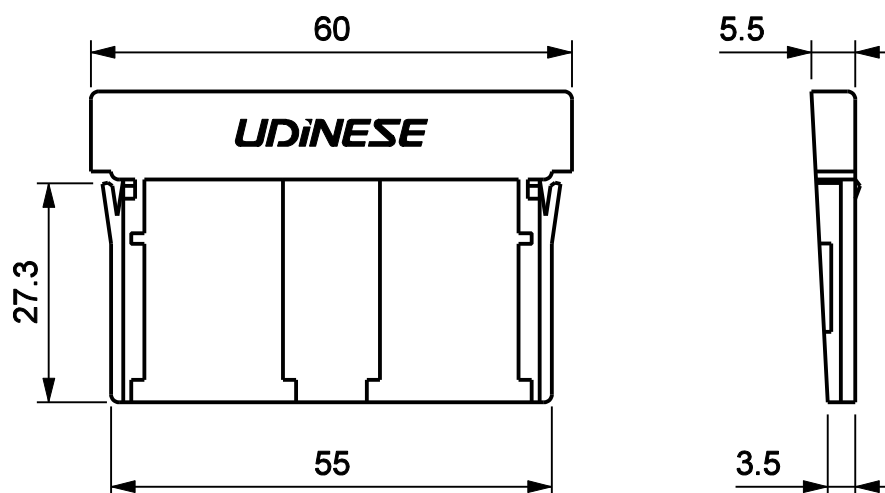
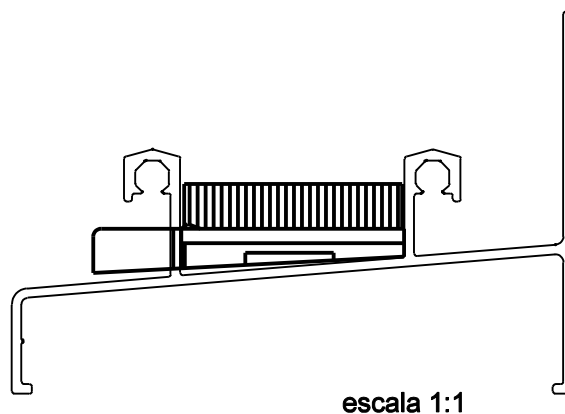

DETALHE DE USINAGEM escala 1:1

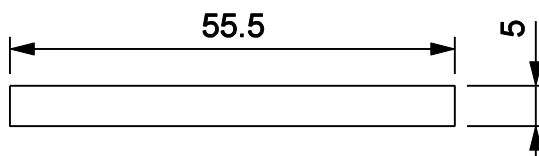

*Todas as medidas em mm

UDINESE

250.45.1

JANELA E PORTA DE CORRER
OFFICIAL