

FECHO CONCHA 8611

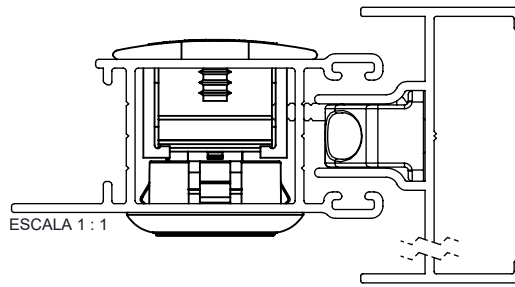

APLICAÇÃO



CARACTERÍSTICAS

CODIFICAÇÃO			
FECHO CONCHA 8611/A			
COR	CÓDIGO	CATÁLOGO	SISTEMISTA
BCO	9211418	CON8611ATHBCO	CON-8611
BP3	9211419	CON8611ATHBP3	
PRA	9211420	CON8611ATHPRA	
PTF	9211421	CON8611ATHPTF	
INX	9211422	CON8611ATHINX	

CODIFICAÇÃO			
FECHO CONCHA 8611/A/CHAVE			
COR	CÓDIGO	CATÁLOGO	SISTEMISTA
BCO	9211423	CON8611ACTHBCO	CON-8611
BP3	9211424	CON8611ACTHBP3	
PRA	9211425	CON8611ACTHPRA	
PTF	9211426	CON8611ACTHPTF	
INX	9211427	CON8611ACTHINX	

CONTRA FECHO	
BCO - 9210376	POLÍMERO
PRT - 9210375	

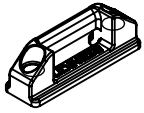

LINGUETA
S/A - 9210395



OBSERVAÇÕES:

- CONTRAFECHO E LINGUETA VENDIDOS SEPARADAMENTE.

COMPOSIÇÃO/CARACTERÍSTICAS:

- CONCHA/ INTERNO/ PINO: ALUMÍNIO;
- INCADOR/TRAVA CONCHA : POLÍMERO;
- MOLLA/ PARAFUSOS/CILINDRO/CHAVE:INOX.

DIMENSÕES

FECHO CONCHA 8611/A

FECHO CONCHA 8611/A/CHAVE

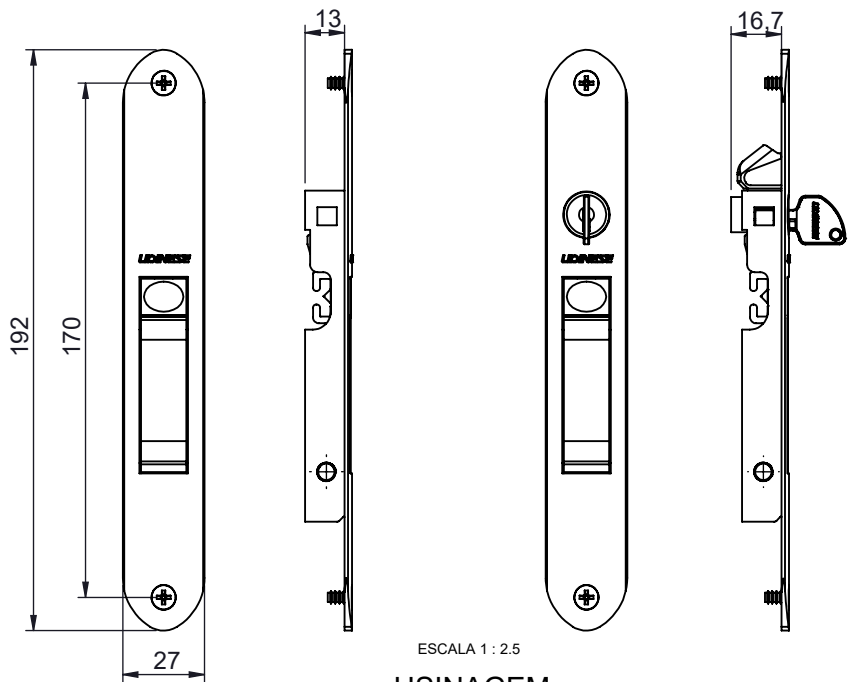

USINAGEM

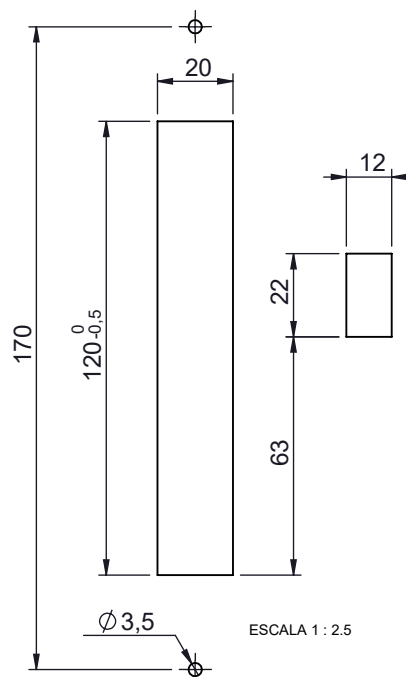

PORTA DE CORRER
HYDRO MASTER

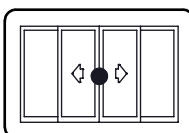

UDINESE
ASSA ABLOY

FECHO CONCHA 8611 SEM PARAFUSO



APLICAÇÃO

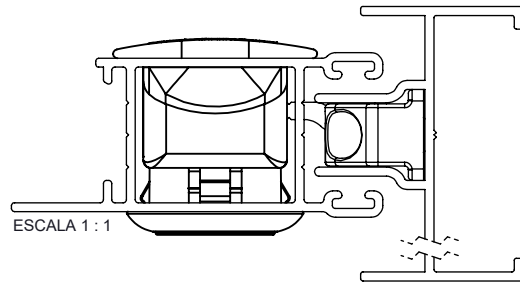

CARACTERÍSTICAS

CODIFICAÇÃO			
FECHO CONCHA 8611/A SEM PARAFUSO			
COR	CÓDIGO	CATÁLOGO	SISTEMISTA
BCO	9211433	CON8611ATHSPARFBCO	CON-8611
BP3	9211434	CON8611ATHSPARFBP3	
PRA	9211435	CON8611ATHSPARFPRA	
PTF	9211436	CON8611ATHSPARFPTF	
INX	9211437	CON8611ATHSPARFINX	

CODIFICAÇÃO			
FECHO CONCHA 8611/A/CHAVE SEM PARAFUSO			
COR	CÓDIGO	CATÁLOGO	SISTEMISTA
BCO	9211438	CON8611ACTHSPARFBCO	CON-8611
BP3	9211439	CON8611ACTHSPARFBP3	
PRA	9211440	CON8611ACTHSPARFPRA	
PTF	9211441	CON8611ACTHSPARFPTF	
INX	9211442	CON8611ACTHSPARFINX	

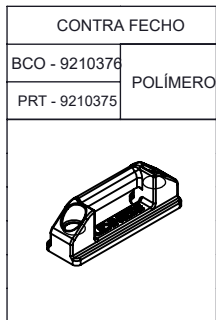

OBSERVAÇÕES:

- CONTRAFECHO E LINGUETA VENDIDOS SEPARADAMENTE.

COMPOSIÇÃO/CARACTERÍSTICAS:

- CONCHA/ INTERNO/ PINO: ALUMÍNIO;
- INCADOR/TRAVA CONCHA : POLÍMERO;
- MOLA/CILINDRO/CHAVE:INOX.

DIMENSÕES

FECHO CONCHA 8611/A SEM PARAFUSO

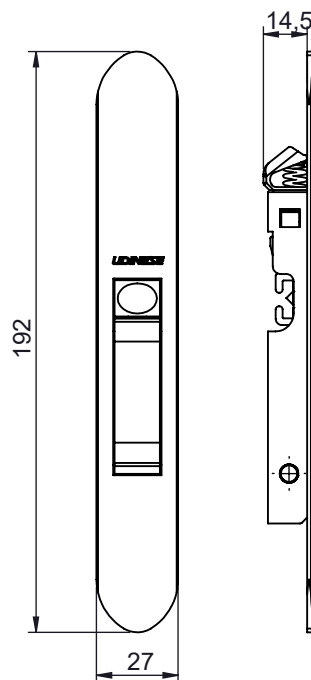

FECHO CONCHA 8611/A/CHAVE SEM PARAFUSO

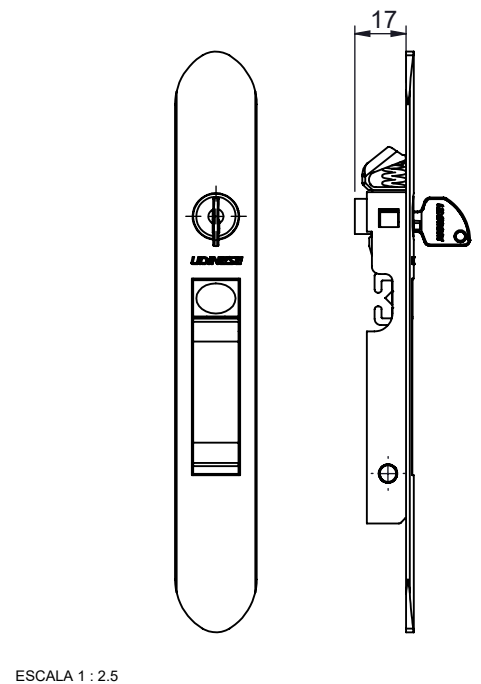

USINAGEM

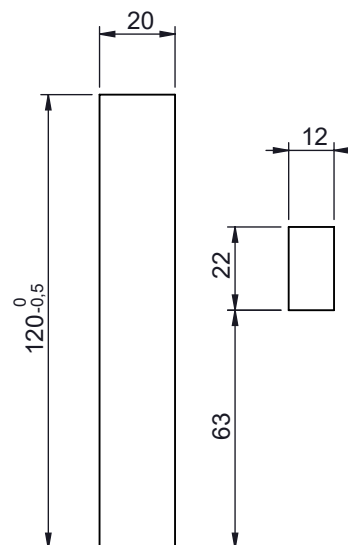

PORTA DE CORRER
HYDRO MASTER

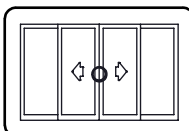

UDINESE
ASSA ABLOY

FECHO CONCHA 8611

INSTRUÇÃO DE MONTAGEM

O INDICADOR DEVE SER MONTADO APÓS O AJUSTE DA LINGUETA, SUA FUNÇÃO É IMPEDIR QUE O PARAFUSO FIQUE APARENTE.

CASO SEJA NECESSÁRIO A REMOÇÃO DO INDICADOR, FORCE-O PELO LADO INFERIOR UTILIZANDO UM OBJETO PONTIAGUDO.

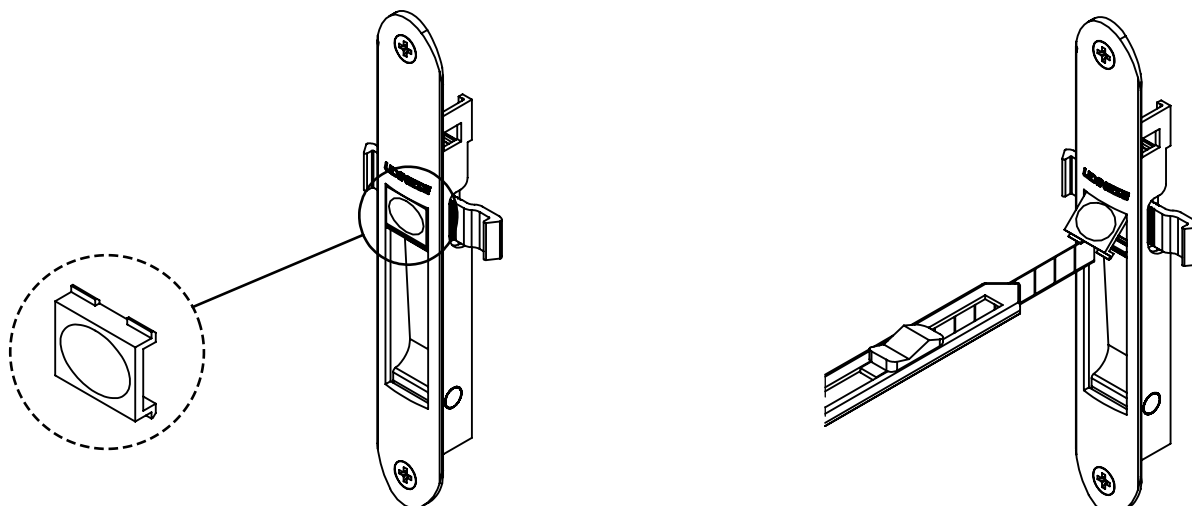

MONTAGEM DO INDICADOR

1. ENCAIXAR A PARTE SUPERIOR DO INDICADOR NO INTERNO DO FECHO CONCHA. CONFORME ILUSTRAÇÃO DA FIG.1:
2. APÓS O ENCAIXE DA PARTE SUPERIOR, PRESSONAR O INDICADOR NA DIREÇÃO E SENTIDO DE F2 ATÉ QUE A PEÇA SEJA CLICADA NO INTERNO CONFORME FIGURAS 1 E 2.

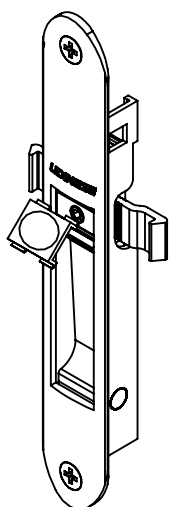

FIG. 1

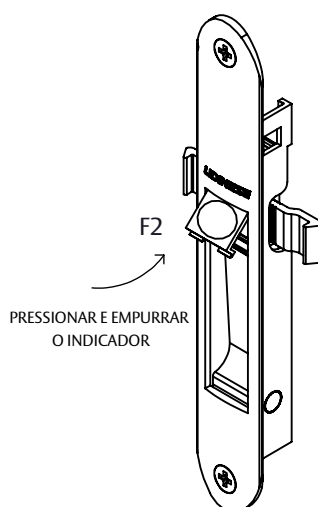

FIG. 2

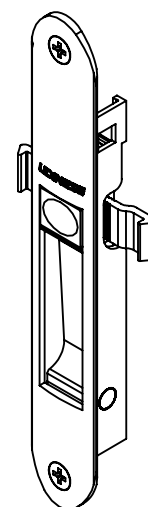

FIG. 3

UDINESE
ASSA ABLOY