

# FECHO MAX-AR 735D SUP C/ BAG S/CTF (FEC009)

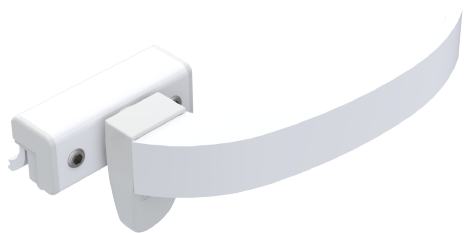

## CARACTERÍSTICAS

CODIFICAÇÃO			
VERSÃO	COR	CÓDIGO	CATÁLOGO
DIR	BCO	9206879	FEC735D52SUBCO
	BP3	9209791	FEC735D52SUBP3
	PRA	9209661	FEC735D52SUPRA
	PTF	9209341	FEC735D52SUPTF
	S/A	9211740	FEC735D52SUS/A
ESQ	BCO	9206883	FEC735E52SUBCO
	BP3	9209792	FEC735E52SUBP3
	PTF	9209369	FEC735E52SUPTF
	S/A	9211774	FEC735E52SUS/A

## OBSERVAÇÕES

### COMPOSIÇÃO/CARACTERÍSTICAS:

- MAÇANETA E BASE: ALUMÍNIO;
- BICO E TAMPAS: NYLON;
- ARRUELA E PARAFUSOS: INOX.

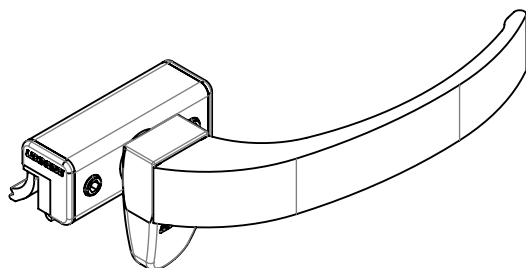

ESCALA 1:2

## APLICAÇÃO

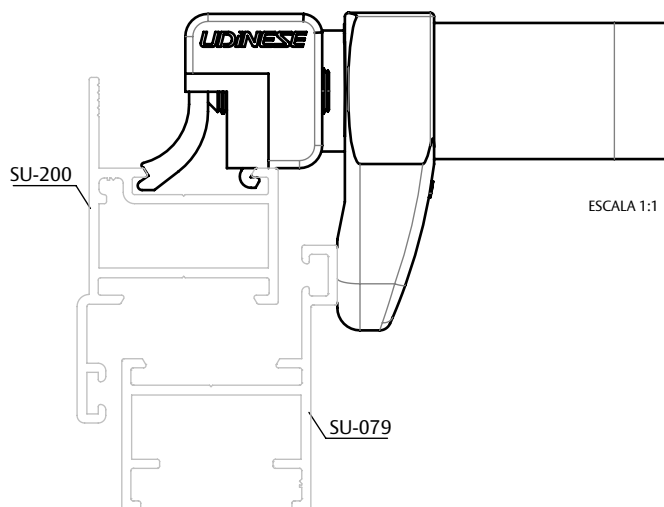

ESCALA 1:1

## DIMENSÕES

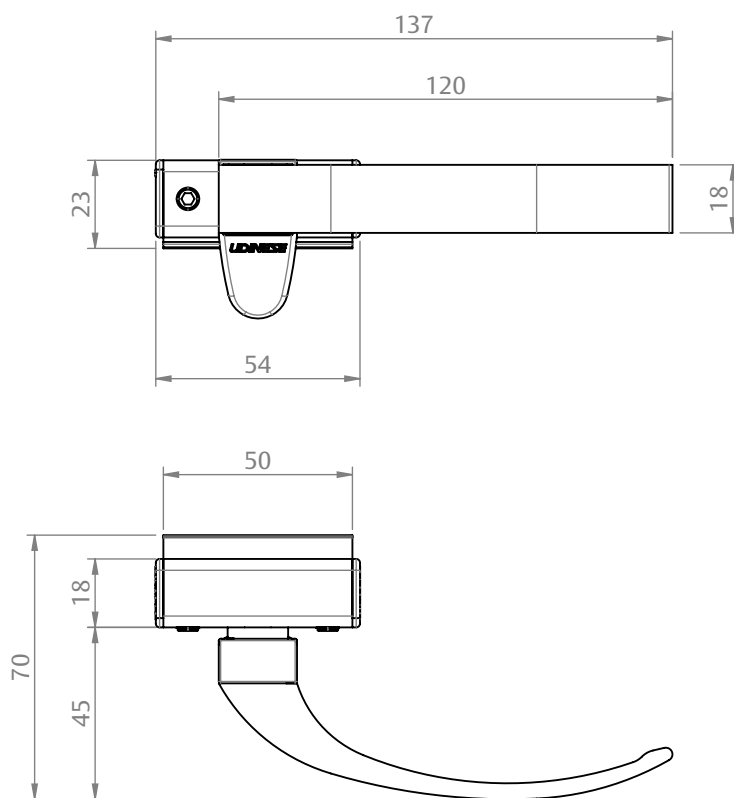

ESCALA 1:2

MAXIM-AR  
SUPREMA

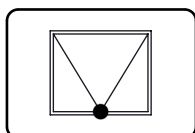

**UDINESE**  
**ASSA ABLOY**