

FECHO MAX-AR 735D SUP SB-SU S/BG C/CTF



CARACTERÍSTICAS

EMBALAGEM		
COMPONENTE	M. PRIMA	QTD
FECHO	ALUMÍNIO	1
CONTRA FECHO	POLÍMERO	1
PARF W3/16X8 PAN/COMB	INOX	2
PARF A3,5X6,5 PAN/COMB	INOX	2

CODIFICAÇÃO

VER	COR	CÓDIGO	CATÁLOGO
DIR	BCO	9206911	FEC735DSBSUBCO
	BP3	9209782	FEC735DSBSUBP3
	PRA	9209665	FEC735DSBSUPRA
	PTF	9209343	FEC735DSBSUPTF
ESQ	BCO	9206915	FEC735ESBSUBCO
	PRA	9209666	FEC735ESBSUPRA
	PTF	9209371	FEC735ESBSUPTF

OBSERVAÇÕES:

PARA FOLHAS ACIMA DE 800MM DE LARGURA É RECOMENDADO O USO DE 2 FECHOS.

APLICAÇÃO

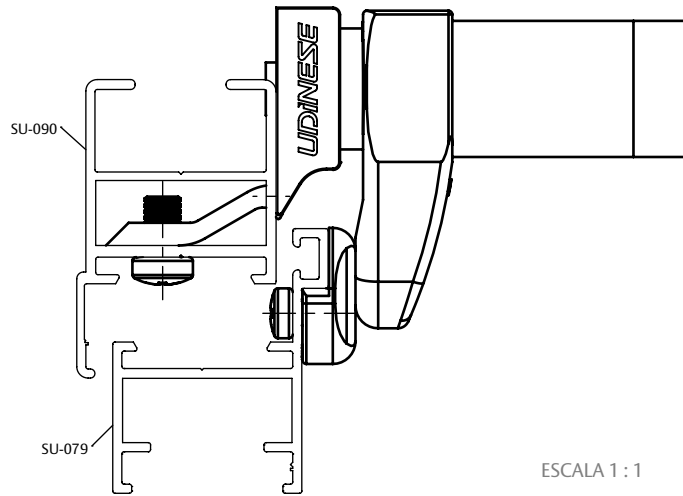

ESCALA 1 : 1

DIMENSÕES

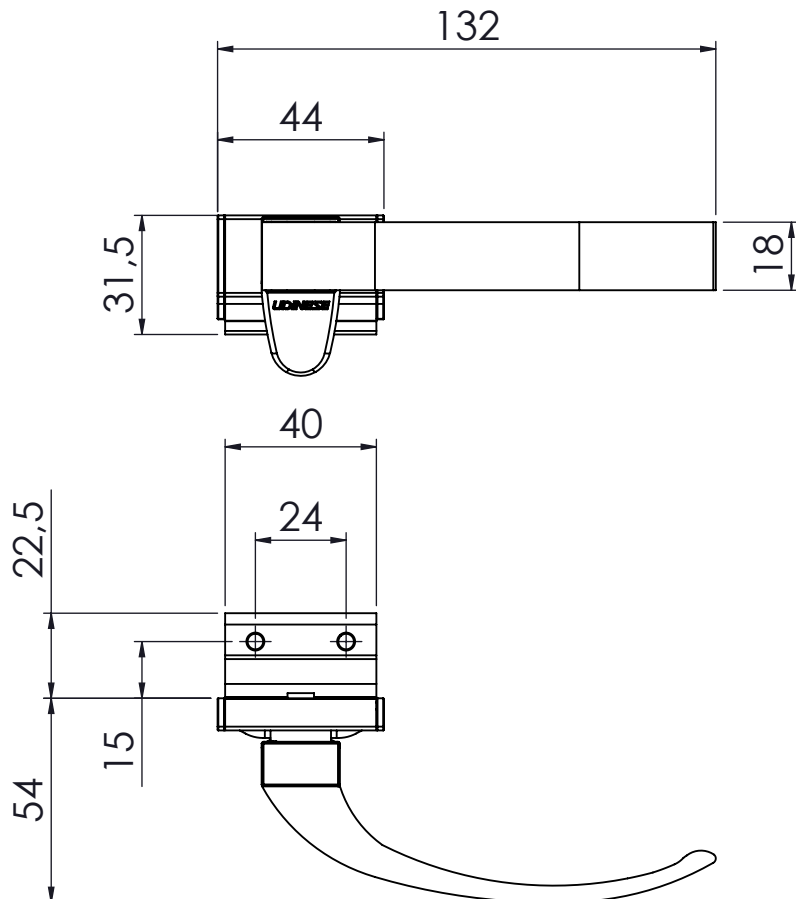

ESCALA 1 : 2

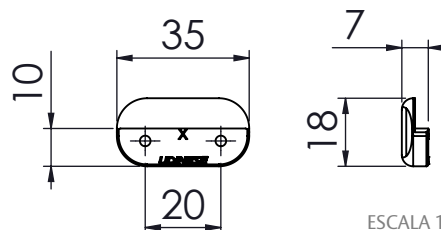

ESCALA 1 : 2

MAXIM-AR
SUPREMA

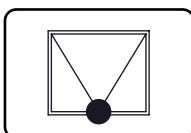

UDINESE
ASSA ABLOY

FECHO MAX-AR 735D SUP SB-SU S/BG C/CTF

INSTRUÇÃO DE MONTAGEM E USINAGEM

IMAGEM MERAMENTE ILUSTRATIVA

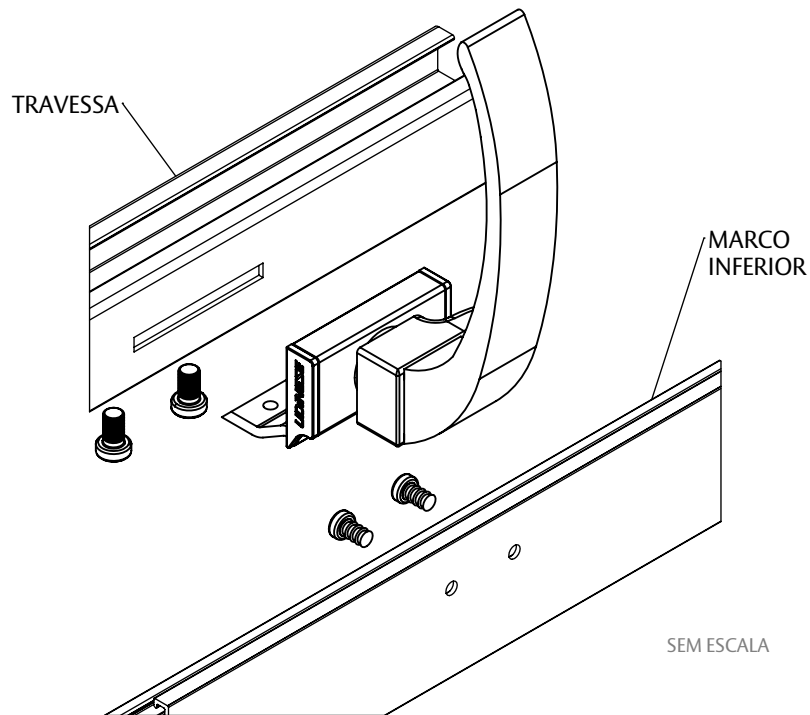

USINAGEM DA TRAVESSA

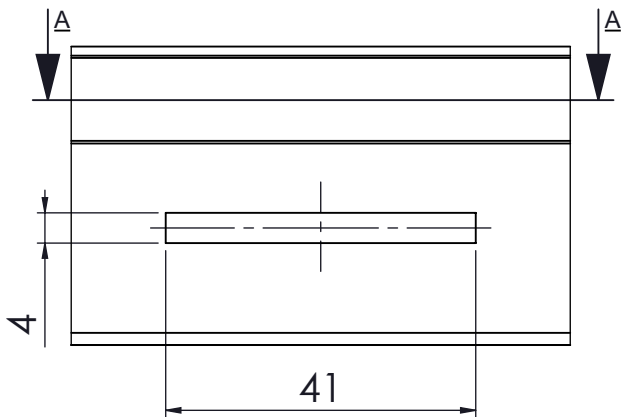

REFERÊNCIA DE USINAGEM

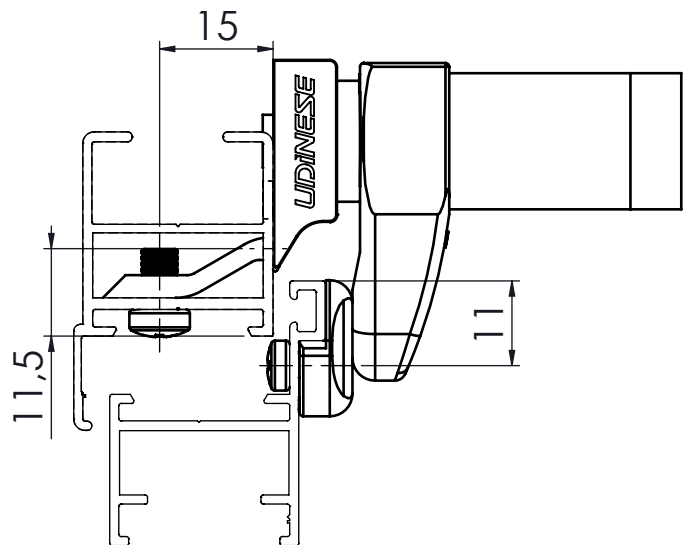

SEÇÃO A-A

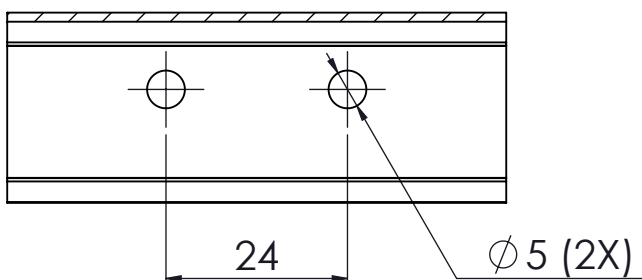

USINAGEM DO MARCO INFERIOR

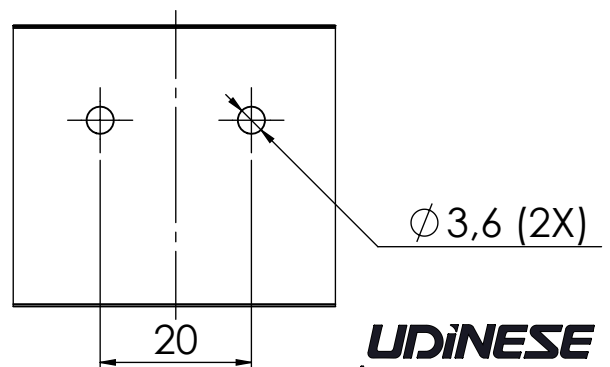

SEM ESCALA

UDINESE
ASSA ABLOY