

# FECHO MAX-AR 735D INF C/CTF B7 C/CALCO



## CARACTERÍSTICAS

### EMBALAGEM

COMPONENTE	M. PRIMA	QTDE
FECHO	ALUMÍNIO	1
CONTRA FECHO	POLÍMERO	1
PARF W3/16X8 PAN/COMB	INOX	2
PARF A3,5X6,5 PAN/COMB	INOX	2

### CODIFICAÇÃO

VER	COR	CÓDIGO	CATÁLOGO
DIR	BCO	9210463	FEC735DINF7CALCOBCO
	PRA	9210464	FEC735DINF7CALCOPRA
	PTF	9210465	FEC735DINF7CALCOPTF
ESQ	BCO	9210466	FEC735EINF7CALCOBCO
	PRA	9210467	FEC735EINF7CALCOPRA
	PTF	9210468	FEC735EINF7CALCOPTF

## APLICAÇÃO

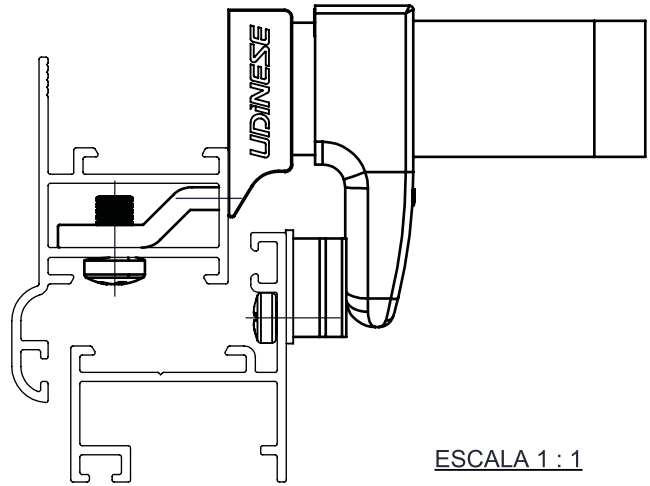

ESCALA 1 : 1

## DIMENSÕES

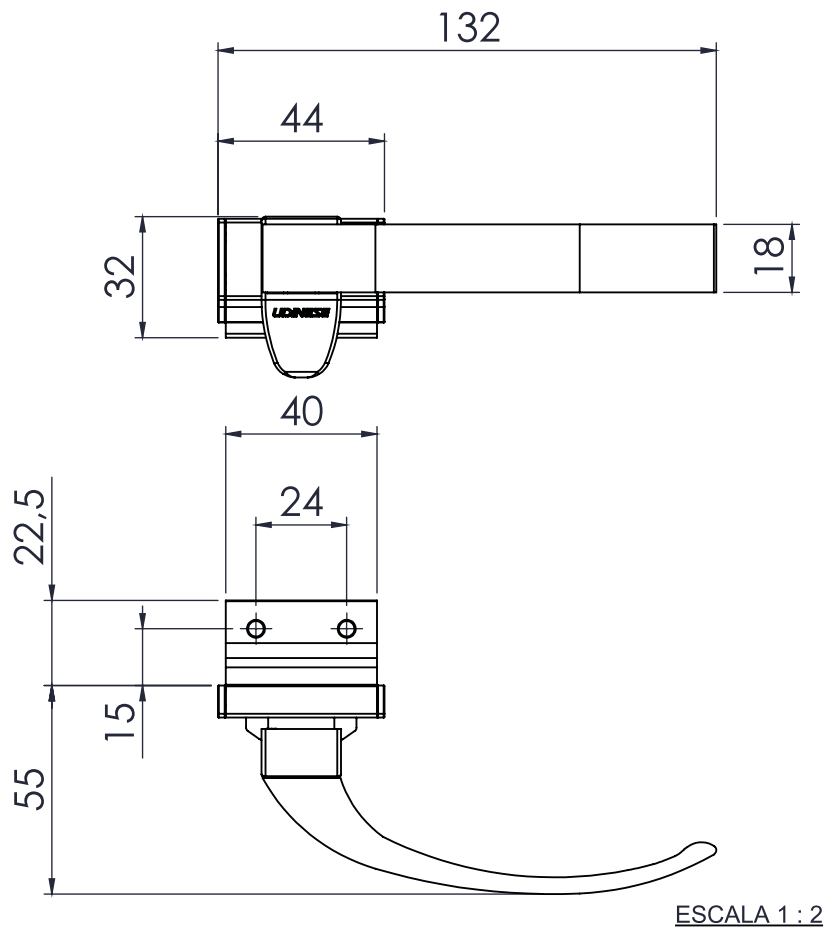

ESCALA 1 : 2

MAXIM-AR  
IMPERIAL 2.5

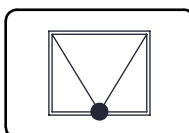

ESCALA 1 : 2

UDINESE

Reservamos o direito de alterações sem aviso prévio. Todas as medidas em mm.

# FECHO MAX-AR 735D INF C/CTF B7 C/CALCO

## INSTRUÇÃO DE MONTAGEM E USINAGEM

IMAGEM MERAMENTE ILUSTRATIVA

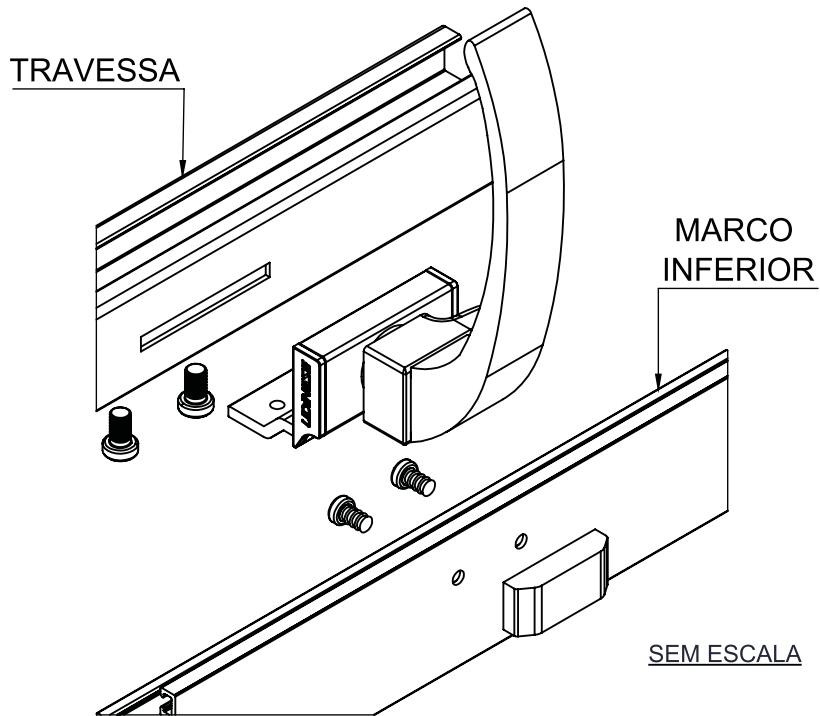

### USINAGEM DA TRAVESSA

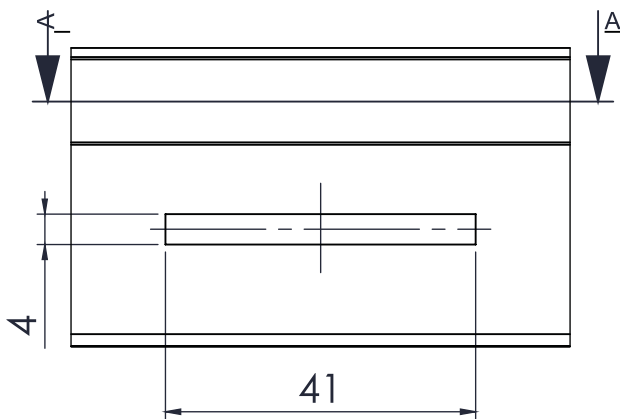

### REFERÊNCIA DE USINAGEM

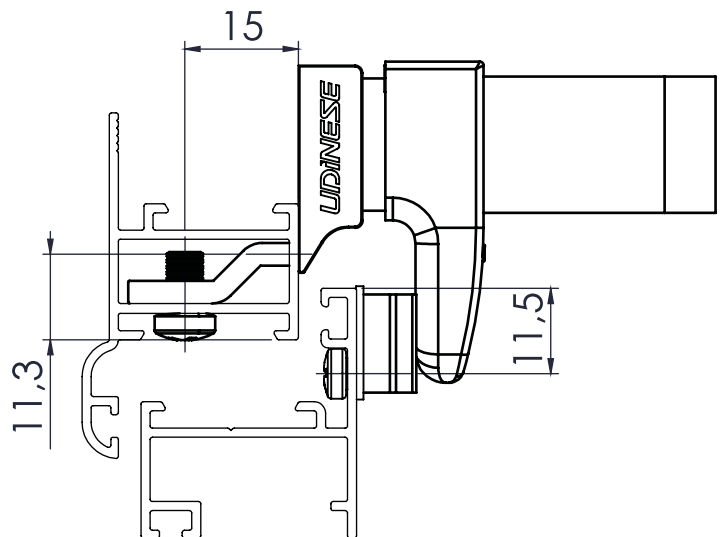

### SEÇÃO A-A

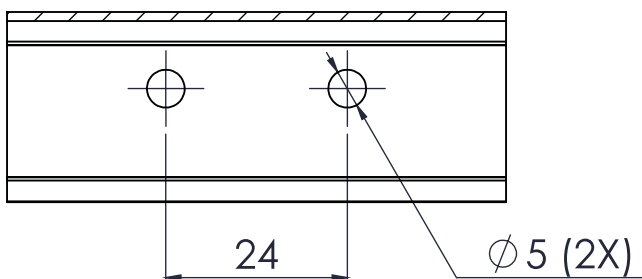

### USINAGEM DO MARCO INFERIOR

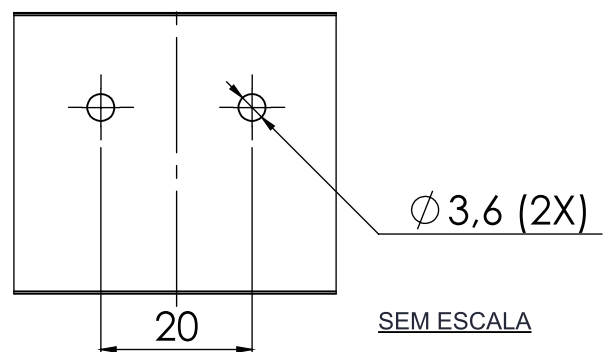

**UDINESE**