

# FECHO UNHA 1900

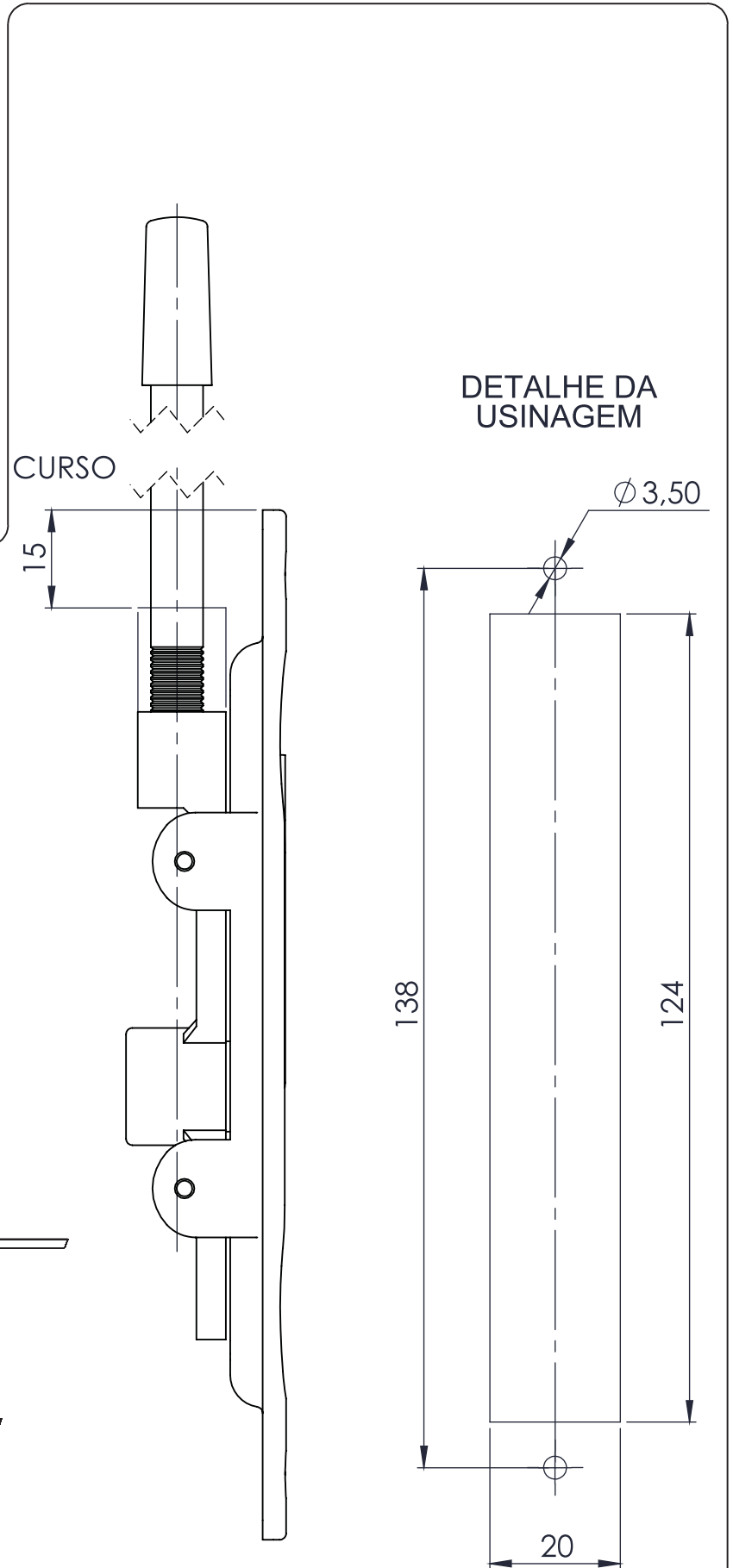

## Características

Componentes	Matéria Prima
Estrutura	ZAMAK
Mecanismo	ZAMAK
Haste	Aço Carbono

Componentes de fixação	Dimensão	Qtde
Parafuso	A4,2 x 8 CHA/PH INOX	2

Embalagem	1 Fecho	
	1 Haste	
	2 Parafusos	

Codificação		
Cor	Udinese	Catálogo
PTF	9209149	FEC1900PTF
BCO	9208995	FEC1900BCO
PRA	9209150	FEC1900PRA

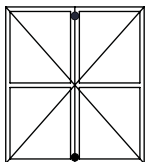
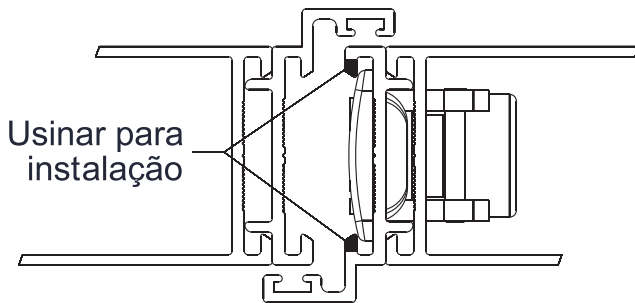

**PORTA DE GIRO  
LINHA GOLD**

\*Todas as medidas em mm

**UDINESE**

# FECCHO UNHA 1900

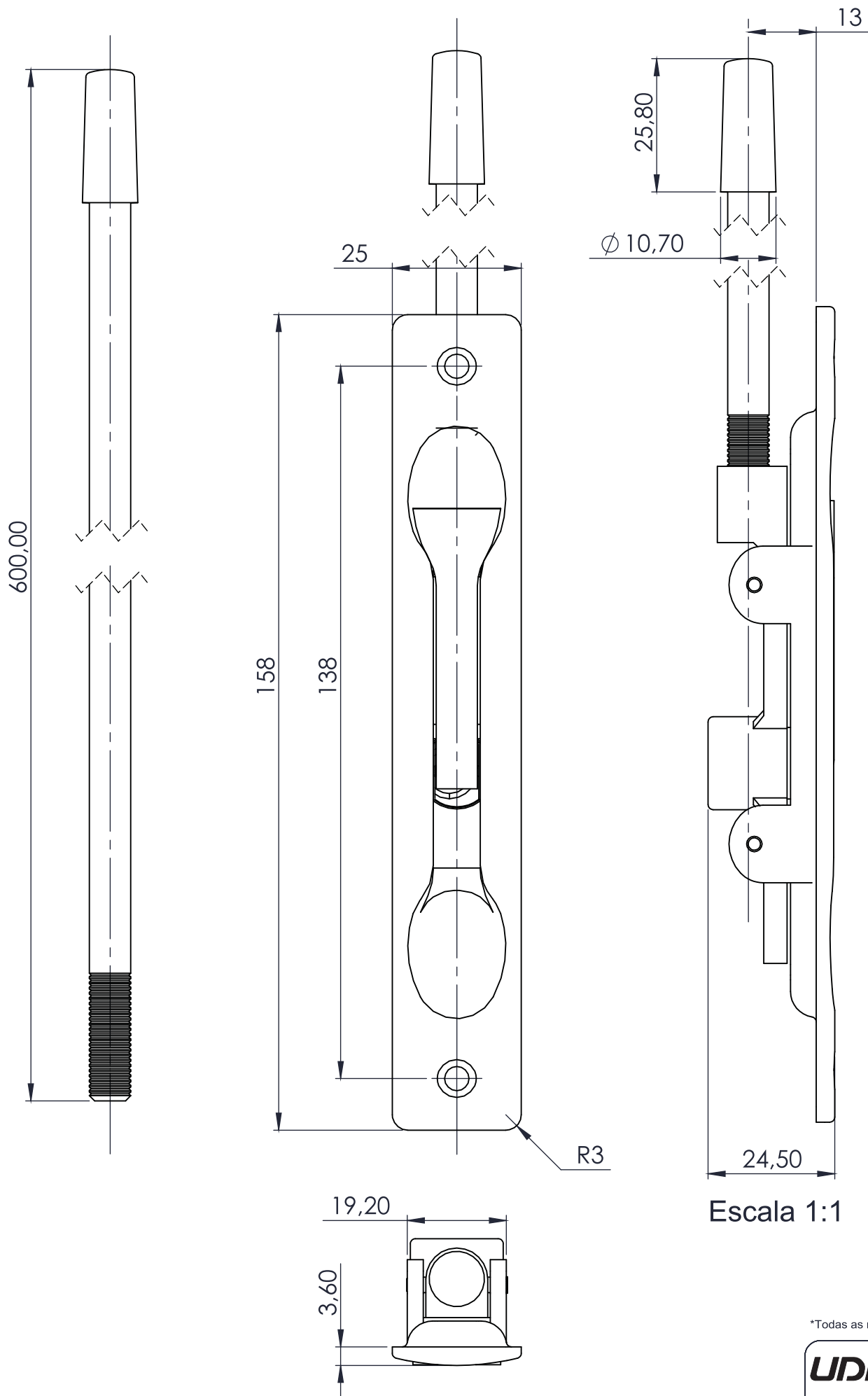

\*Todas as medidas em mm

**UDINESE**