

HASTE SMART

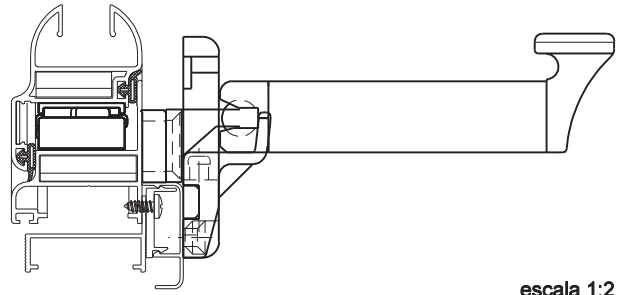

DETALHE DE APLICAÇÃO



escala 1:2

HASTE

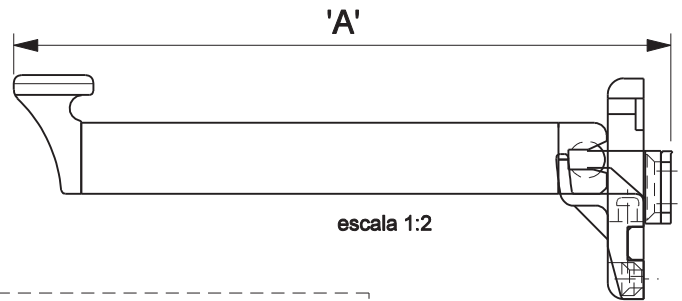

escala 1:2

Características

Componentes	Matéria-prima
Haste	Alumínio
Guia	Polímero
Descanso	Polímero
Base	Polímero
Puxador	Polímero
Articulação	Zamak

Compon. de fixação	Dimensões	Qtde
Parafuso	A4.2x13 cha/ph/inox	6

Embalagem:	1 haste
	1 guia
	1 descanso
	2 calços
	6 parafusos

Codificação			
Dim. 'A'	Cor	Udinese	Catálogo
120	BCO	9102481	HAS120CAL35BCO
	BR3	9102482	HAS120CAL35BR3
	NAT	9102483	HAS120CAL35NAT
	PTF	9102727	HAS120CAL35PTF
200	BCO	9102433	HAS200CAL35BCO
	BR3	9102434	HAS200CAL35BR3
	PRA	9102758	HAS200CAL35PRA
	PTF	9102730	HAS200CAL35PTF
250	BCO	9102437	HAS250CAL35BCO
	BR3	9102438	HAS250CAL35BR3
	PRA	9102759	HAS250CAL35PRA
	PTF	9102734	HAS250CAL35PTF
300	BCO	9102441	HAS300CAL35BCO
	BR3	9102442	HAS300CAL35BR3
	PRA	9102443	HAS300CAL35NAT
	PTF	9102738	HAS300CAL35PTF
400	BCO	9102445	HAS400CAL35BCO
	BR3	9102446	HAS400CAL35BR3
	PRA	9102760	HAS400CAL35PRA
	PTF	9102743	HAS400CAL35PTF

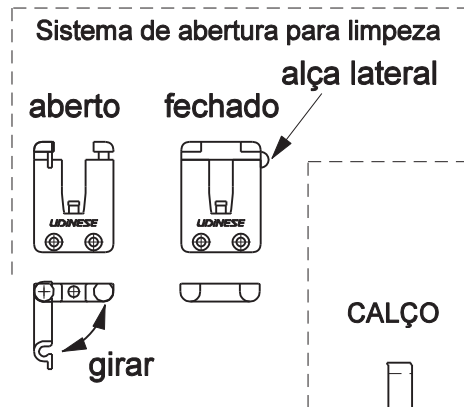

CALÇO

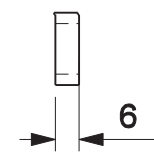

escala 1:2

GUIA

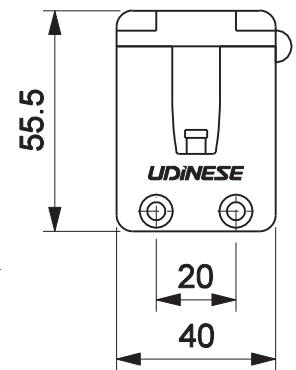

USINAGEM

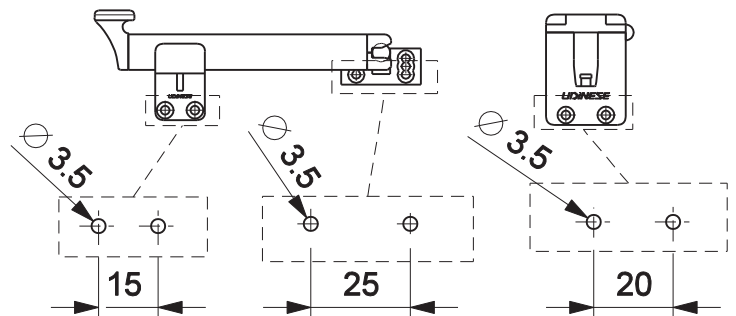

escala 1:4

JANELA MAXIM-AR
LINHA IMPERIAL 3.5

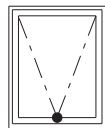

UDINESE