

MAÇANETA CREMONA MAX-AR SLIM GARFO L32 MASSIMA SL



CARACTERÍSTICAS

CODIFICAÇÃO		
COR	CÓDIGO	CATÁLOGO
BCO	9212583	MACCRESLIMMASSLBCO
CZA 9007	9212584	MACCRESLIMMASSLCZ7
PTF	9212585	MACCRESLIMMASSLPTF
S/A	9212586	MACCRESLIMMASSLS/A

OBSERVAÇÕES

COMPOSIÇÃO/CARACTERÍSTICAS:

- BASE E MAÇANETA: ALUMÍNIO;
- CAPA INTERNA E SUPORTE: POLÍMERO;
- MECANISMO: ZAMAK;
- PARAFUSOS: AÇO INOX.

USINAGENS MAÇANETA CREMONA

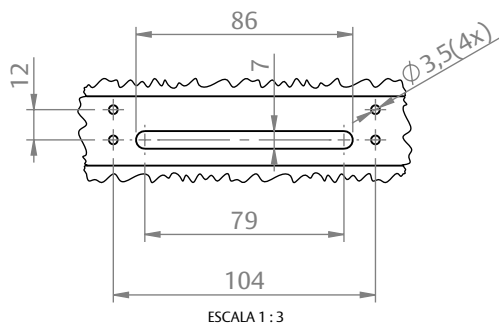

SUPORTE LIGAÇÃO MAÇANETA CREMONA

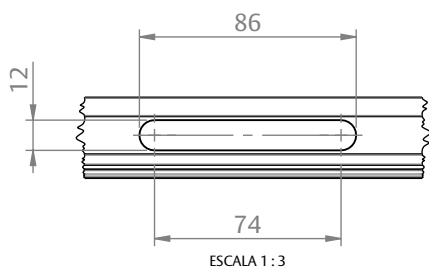

CORRER/ALÇANTE
EURO MASSIMA SL/CL

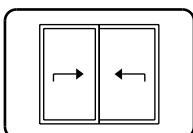

APLICAÇÃO

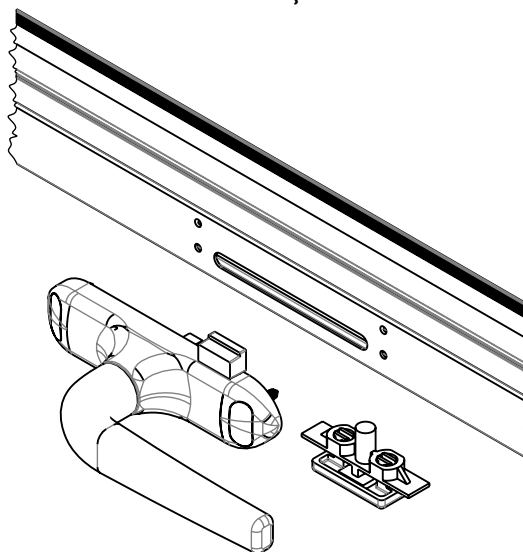

DIMENSÕES MAÇANETA CREMONA

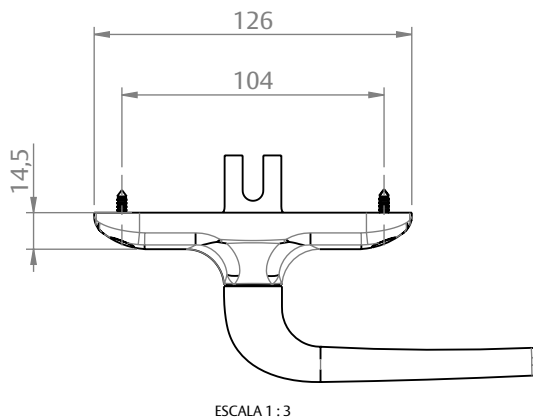
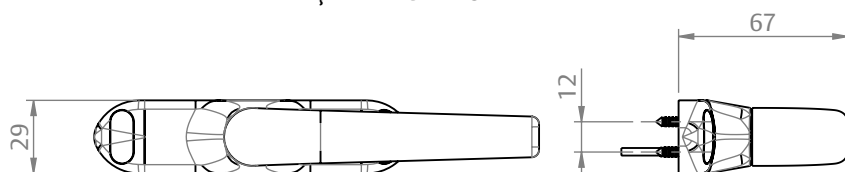

SUPORTE LIGAÇÃO MAÇANETA CREMONA

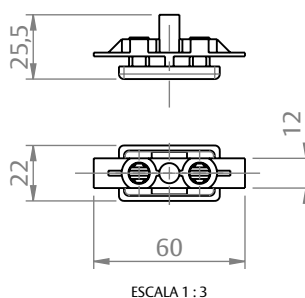

UDINESE
ASSA ABLOY