

RECOLHEDOR 8118/40

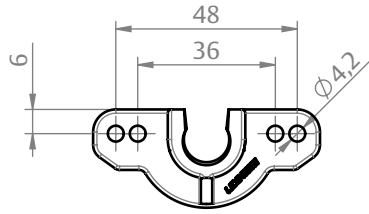

APLICAÇÃO

MANCAL



USINAGEM

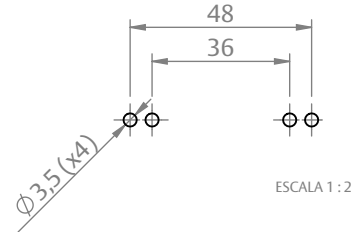

CARACTERÍSTICAS

CODIFICAÇÃO

COR	CÓDIGO	CATÁLOGO	SISTEMISTA
BCO	9901489	REC8118/40-EB-CZ	
BCO	9901490	REC8118/40EB-CP	
PRT	9901488	REC8118/40EP-CP	

OBSERVAÇÕES:

- COMPRIMENTO DA CINTA: 5,50 M;
- ALTURA MÁXIMA: 2,40 M;
- CALÇO E ADAPTADORES P/ TUBO DE 60 SÃO VENDIDOS SEPARADAMENTE.

COMPOSIÇÃO/CARACTERÍSTICAS:

- CAIXA DO RECOLHEDOR/ ESPELHO/ MANCAL: POLÍMERO
- PONTEIRA: ALUMÍNIO;
- PARAFUSOS: AÇO INOX;

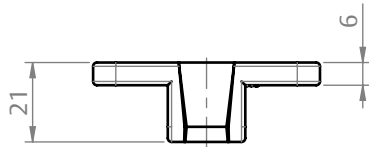

ESCALA 1:2

POLIA

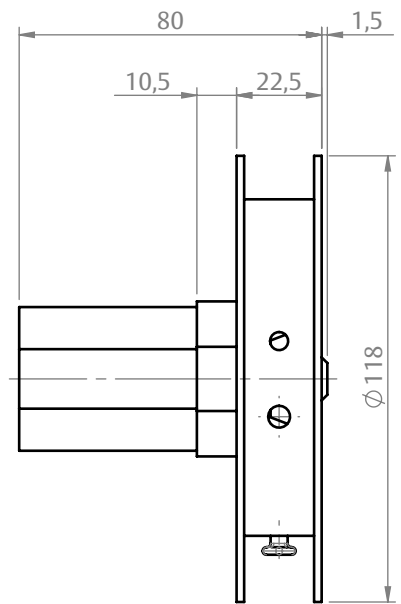

ESCALA 1:2

PONTEIRA OCT40

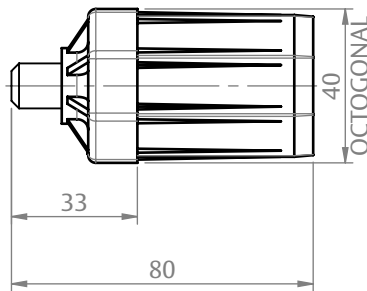

ESCALA 1:2

USINAGEM

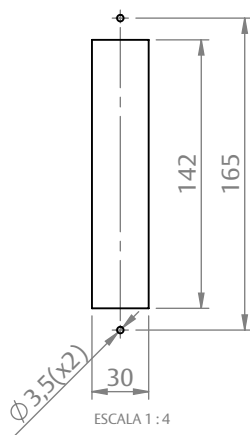

CAIXA DO RECOLHEDOR

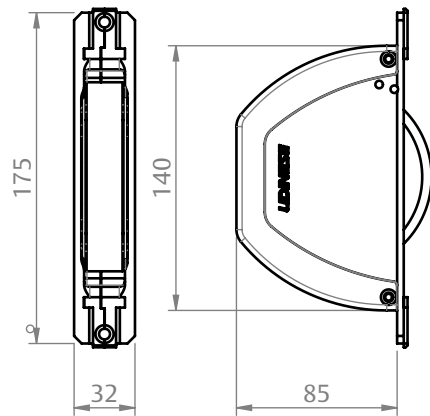

ESCALA 1:4

ESPELHO

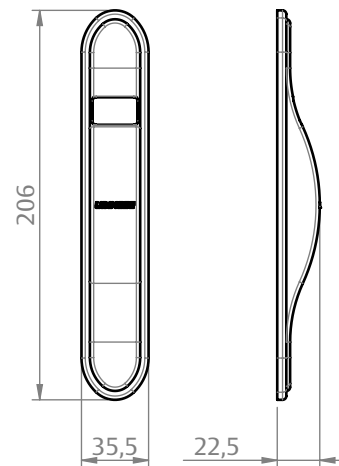

ESCALA 1:4

PERSIANAS

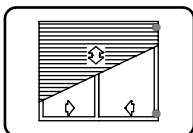

UDINESE
ASSA ABLOY

RECOLHEDOR 8118/40

OBSERVAÇÕES:

- PARA A MONTAGEM COM O TUBO OCTAGONAL DE 40 MM, SEGUIR A MESMA ORDEM DE MONTAGEM DESCONSIDERANDO OS ADAPTADORES PARA TUBO DE 60 MM.

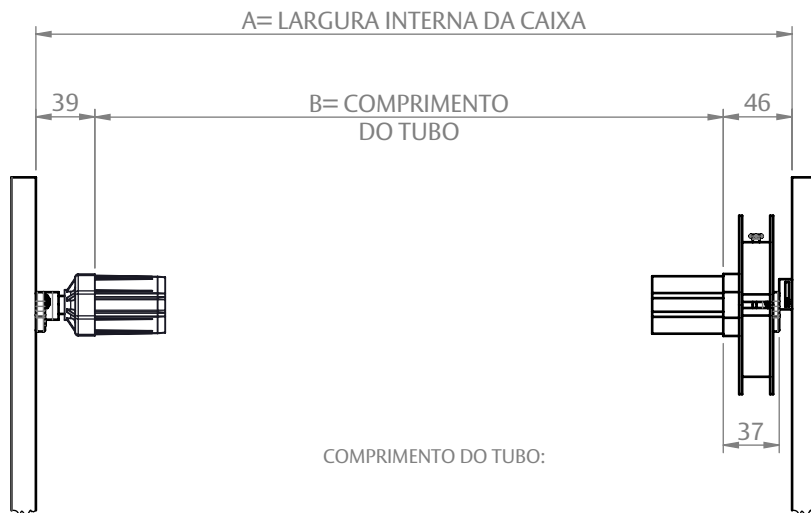
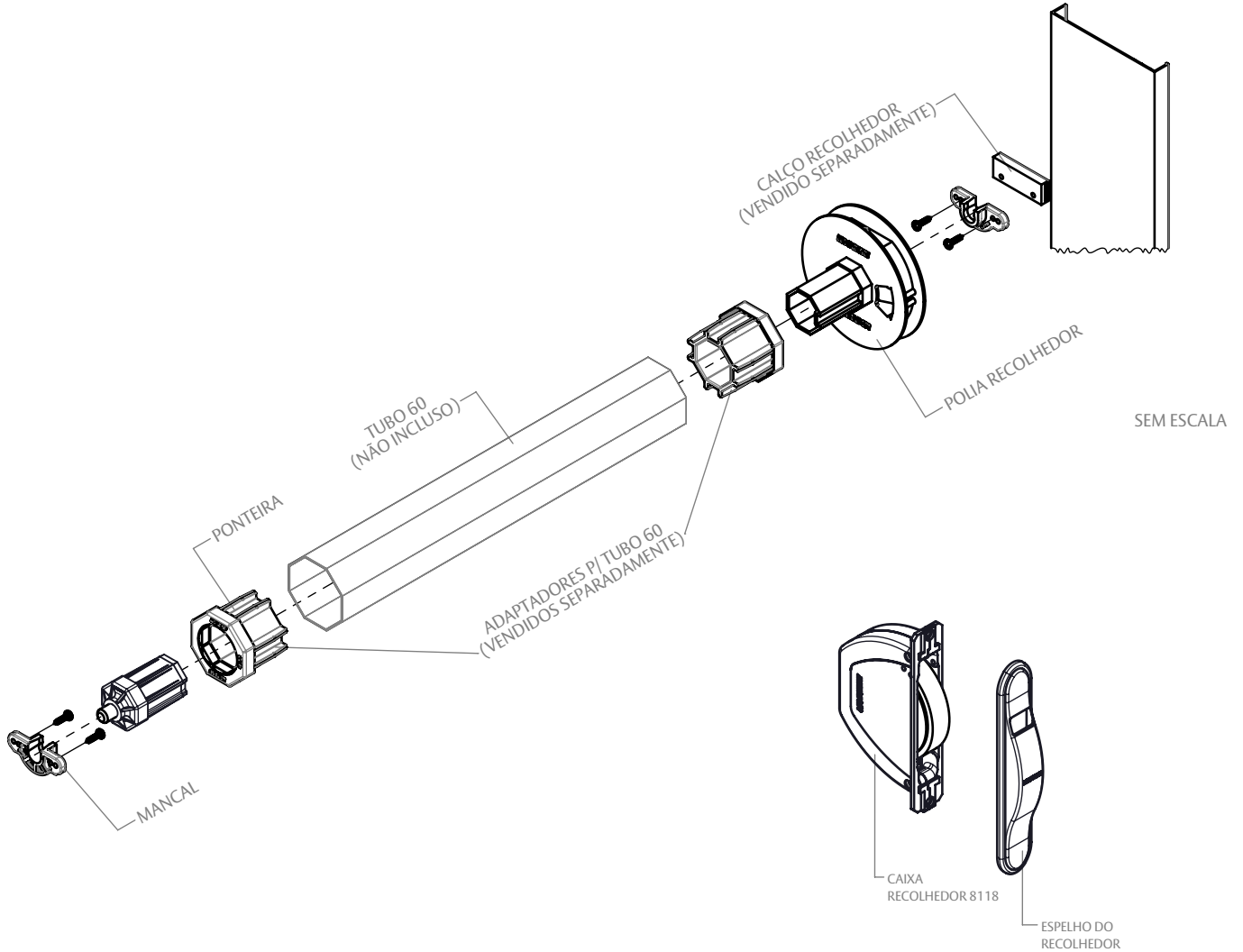

COMPRIMENTO DO TUBO:

B= A- 85 (C/ CALÇO)

B= A- 76 (S/ CALÇO)

UDINESE
ASSA ABLOY