

ROLDANA UDISUPER 300KG GOLD/IMPERIAL/ELG300

CARACTERÍSTICAS

EMBALAGEM		
COMPONENTES	M. PRIMA	QTDE
Roldana Udisuper	Estrutura em alumínio	01
	Rodízios em polímero	
Parafuso A4.2 pan/ph	Inox	02

CODIFICAÇÃO	
CÓDIGO	CATÁLOGO
9500426	ROLUDSPR300GLD

CARGA MÁXIMA
150kg por Roldana

APLICAÇÃO

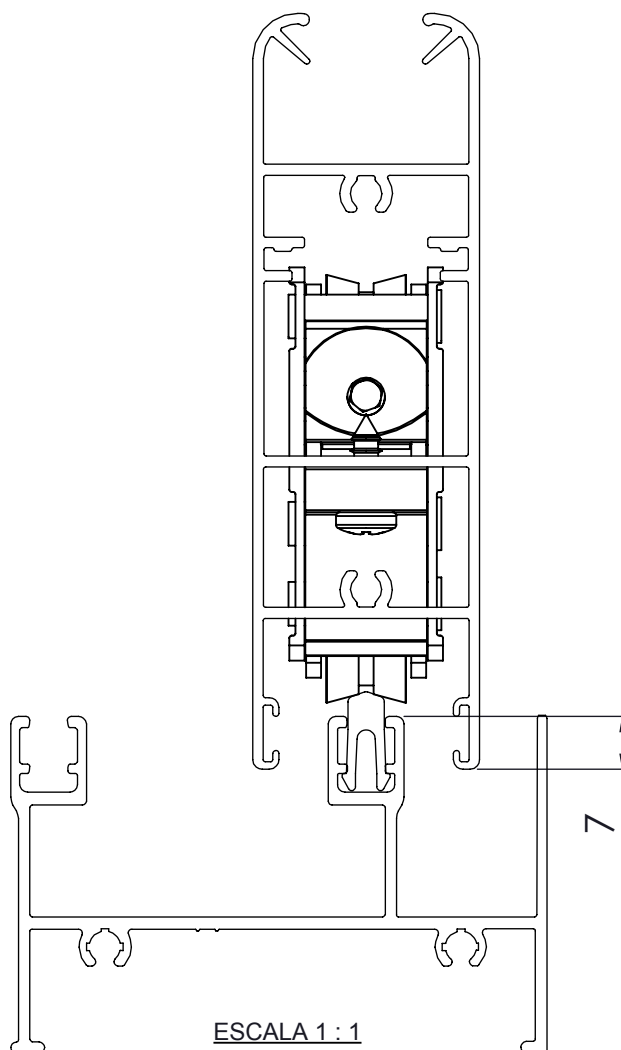

DIMENSÕES

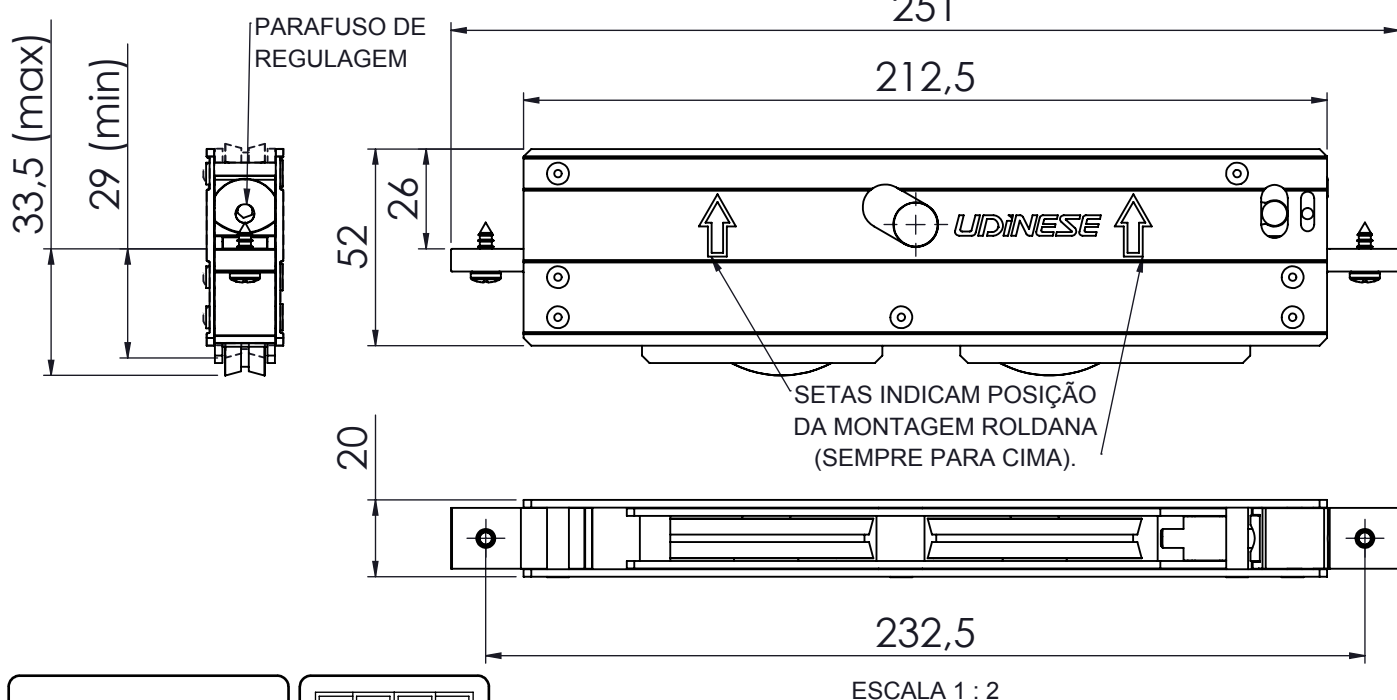

PORTA DE CORRER
ELEGANCE

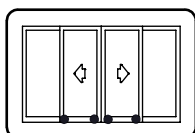

UDINESE

ROLDANA UDISUPER 300KG GOLD/IMPERIAL/ELG300

DETALHES DE USINAGENS

TRAVESSA

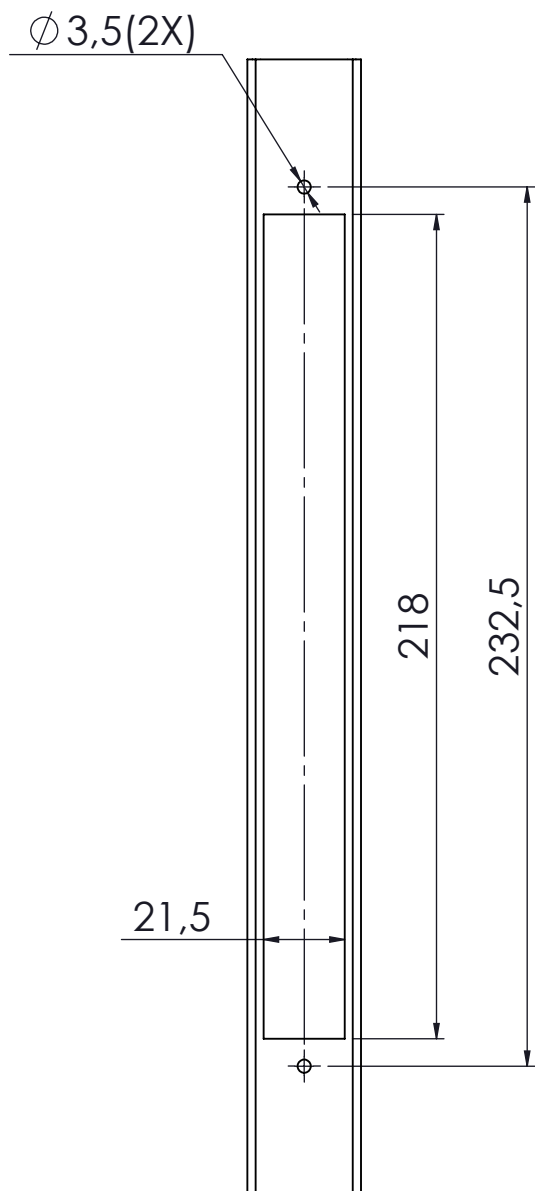

MONTANTE

