

# TAMPA MONTANTE TAM-795/796



## CARACTERÍSTICAS

CODIFICAÇÃO			
COR	CÓDIGO	CATÁLOGO	SISTEMISTA
BCO	9302296	TAM795796NYBCO1PA	TAM-796
PRT	9302295	TAM795796NYPRT1PA	

### OBSERVAÇÕES

#### COMPOSIÇÃO/CARACTERÍSTICAS:

- TAMPA: POLÍMERO;

#### APLICAÇÃO NOS PERFIS:

VT-797; VT-798; VT-844; VT-847; VT-849; VT-861; VT-897.

## APLICAÇÃO

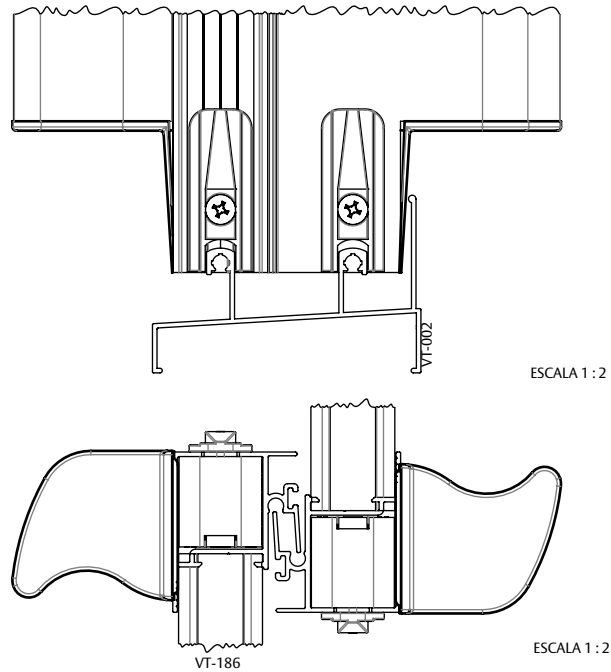

## USINAGEM

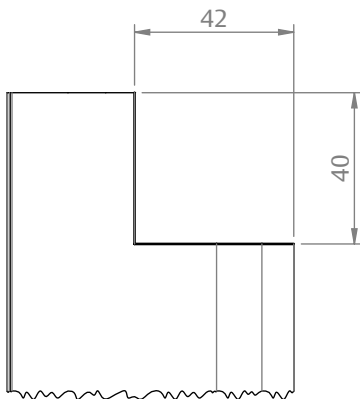

ESCALA 1:2

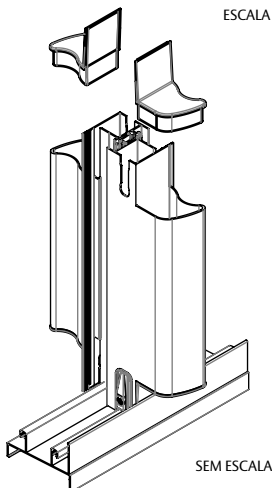

SEM ESCALA

## DIMENSÕES

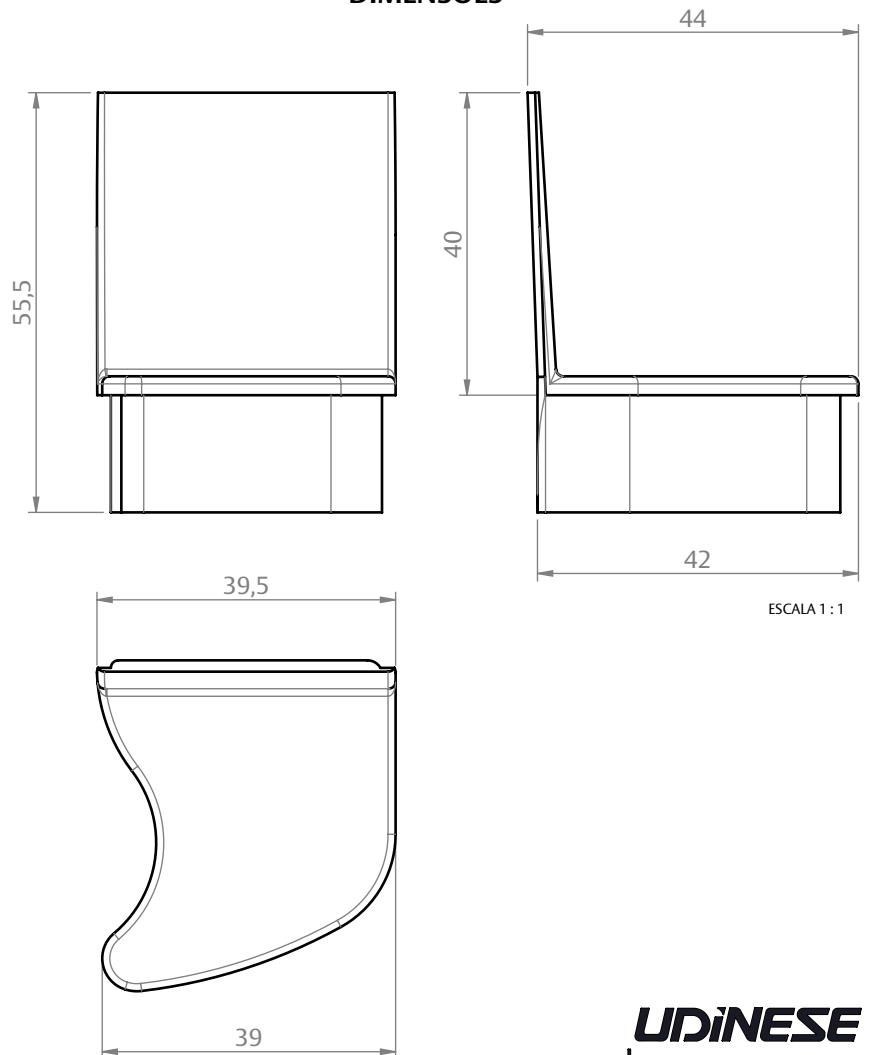

ESCALA 1:1

PORTA E JANELA  
DE CORRER  
ECOLINE 2.5

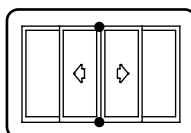

**UDINESE**  
**ASSA ABLOY**